

# GLAZING SYSTEMS FOR DRAINED & VENTILATED FRAMES

## THE D8 DRAINED SECURITY GLAZING SYSTEM

### DESCRIPTION

The D8 Drained Glazing System is suitable for installing all types of single glass and double glazed units into drained timber frames with external beads. For internal beads contact Technical Services. The system comprises Profile Tape, a closed cell EPDM rubber glazing tape coated with adhesive on one side.

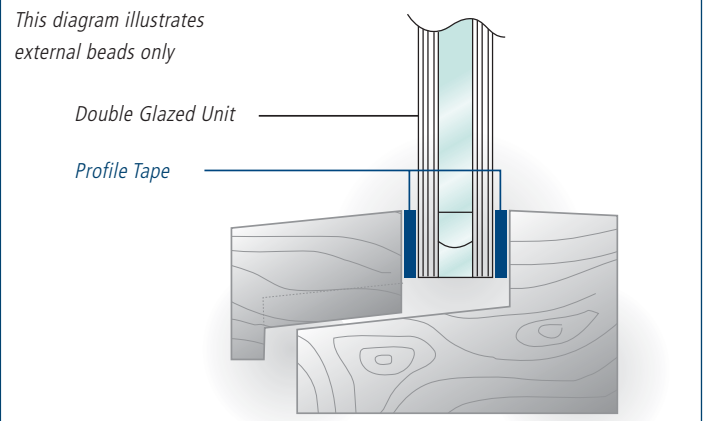

*Note: Silfix® U9 may also be required to comply with BS 8000: Part 7 Clause 2.2.1(e) sealing of frame section junctions and fabrication holes, prior to glazing.*

### EXPOSURE/WEATHERTIGHTNESS RATING

- Suitable for a 1600 Pa 'Medium' Exposure Rating. In certain circumstances this glazing system can achieve a higher exposure, contact Technical Services

### INDUSTRY STANDARDS COMPLIANCE

- BS 6262 Reference 9.3.3.7
- BS 8000 Reference 3.4.1.2
- GGF Manual Section 4.2 Reference IG2
- Zurich New Build Guarantee Ref 2.56
- HAPM CLM
- NHBC Chapter 6.7 Clauses D7 and D4

### MAINTENANCE

Regular maintenance of the frame is essential to ensure maximum performance of the glazing system and double glazed unit.

### WHY CHOOSE THE D8 DRAINED GLAZING SYSTEM

- It provides excellent durability and movement accommodation
- Suitable for glazing all glass types in the factory
- Easy to apply in the factory

### SPECIFICATION CLAUSE

Hodgson D8 Drained Security Glazing System Glazed In Accordance With The Method Statement For The D8 Glazing System.

**Hodgson Sealants Limited**

Belprin Road, Beverley, East Yorkshire,  
HU17 0LN, United Kingdom

**T:** +44 (0)1482 868321  
**F:** +44 (0)1482 870729

**W:** [www.hodgsonsealants.com](http://www.hodgsonsealants.com)  
**E:** [sales@hodgsonsealants.com](mailto:sales@hodgsonsealants.com)

## GLAZING SYSTEM D8 METHOD STATEMENT

Page 2

### MATERIALS REQUIRED

- Profile Tape (closed cell EPDM rubber tape)
- Silfix® U9 silicone sealant
- Setting blocks sized to suit the rebate design, unit thickness and edge clearance
- Location blocks sized to suit the unit thickness and edge clearance
- Bead blocks if required - check window rebate design
- Sheradised glazing pins

### USEFUL TOOLS & ACCESSORIES

- Glazing shovel
- Scissors
- Glass cleaner

### MEASURING THE FRAME OPENING

Any moisture that permeates to the rebates in a drained frame must be rapidly removed. It is important therefore that the double glazed unit is positioned to facilitate drainage in the bottom rebate and maximise ventilation around all rebates. Ensure that the required unit size is calculated after each opening has been correctly measured to ascertain the tight size (see picture A) and the required edge clearances have been determined.

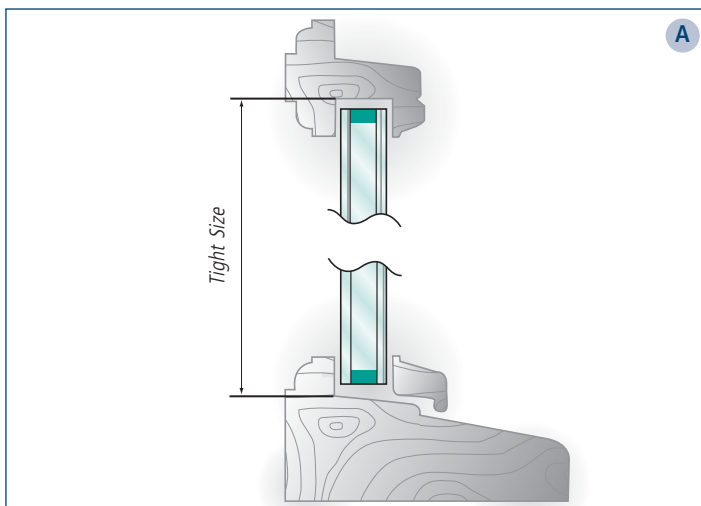

### CALCULATING THE UNIT SIZE

The spacer bar of the unit should ideally be at or slightly below the sightline. The minimum edge clearance for the bottom rebate is 5mm and for the sides and top the minimum is 3mm. Consult the window frame manufacturer if in doubt.

*Example: For frames designed to give 5mm edge clearance on all 4 sides (18mm rebate upstands on all 4 sides) the required glass size will be:- tight rebate size minus 10mm.*

### PREPARATION

1. Check that the moisture content of the window does not exceed 17% as per NHBC Chapter 6.7.
2. Remove all beads from the window and pencil mark the bottom bead on the outside at 150mm centres and no more than 50mm from each end. Make a corresponding mark on the rebate platform. These pencil marks will show you where to position the bead blocks (if required) and pins when pinning the bead.
3. Remove all dust, grease and loose material from the rebate. Any moisture on the timber should be wiped off using a clean paper towel or other absorbent material to give a dry surface.
4. Check the condition of any primer or stain on the frame, especially the rebate and glazing surfaces of the beads. Any section which has been partially missed or is considerably weathered should be reprimed or stained before glazing.
5. Check that the unit fits into the frame and can be centralised when standing the unit on setting blocks so that there is a minimum 5mm edge clearance at the bottom of the unit. The spacer bar should ideally be level with the sightline or slightly below it (see picture B).
6. Apply Silfix® U9 to the bottom half of all joints in the rebate upstand and all rebate platform to platform joints to seal any gaps which are present or may open up (see picture C).

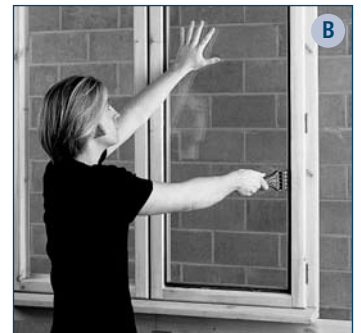

### PREPARATION OF THE DOUBLE GLAZED UNIT

1. Inspect the double glazed unit for obvious defects and wipe any dust or loose material off the unit. Cut away excess edge sealant from the face of the glass.

## GLAZING SYSTEM D8 METHOD STATEMENT

### GLAZING OF FRAMES

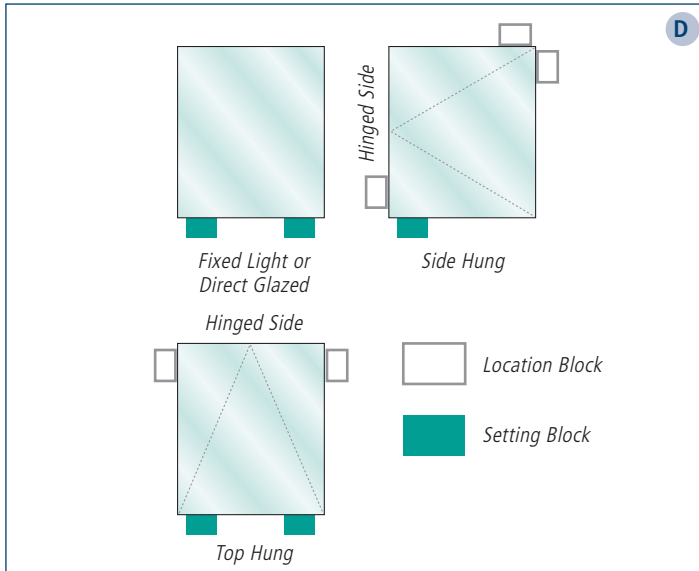

1. All double glazed units must be positioned on setting blocks. If the window has an opening sash, each unit will need to have its weight supported by location blocks in addition to the setting blocks. The position of setting and locations blocks depends on the way the sash is hung. Check picture D above to select the correct position of location and setting blocks appropriate to the window to be glazed.

2. Remove the backing paper and apply Profile Tape for the back beading to the rebate upstand. Start in the bottom corner and apply the tape so that the top edge is level with the sightline. Cut to the correct length. Press firmly to ensure adhesion (see picture E).



3. Start the application of the second length of Profile Tape to the side rebate by forming a butt joint against the length already positioned, taking care to line the edge of the second length of tape with the sightline (see picture F). Apply the tape to both sides and the top.

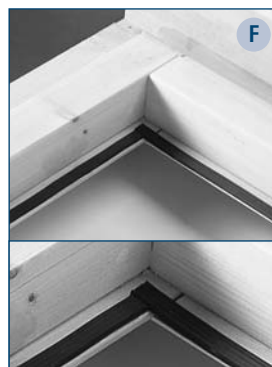

4. Position the setting block(s) on the bottom rail as shown on picture D. Where more than one unit per window is to be glazed, start by glazing the bottom unit(s).

5. Place the unit on setting blocks and centralise in the frame. If glazing an opening sash insert location blocks as shown in picture D.

6. Apply Profile Tape with the adhesive side to the glazing bead and the edge of the Profile Tape level with the sightline of the bead. Press firmly to ensure adhesion. Apply to all 4 beads (see picture G).



7. Align the bead blocks (if required) with the front edge of the bottom rebate platform no more than 50mm from either end and not more than 150mm apart (where the pencil marks should already be). A minimum of 2 blocks must be used for the bottom bead.

8. Place the bottom bead against the unit and position the pins at right angles to the surface of the bead. They should be no more than 50mm from either end and not more than 150mm apart. There should be at least two pins for every bead. It is advisable to use shorter glazing pins when pinning beads to the midrails found on some horizontal and all bar window styles. Apply pressure to give about 30% compression of both back and front bedding and pin the bead.

9. Apply the top and side beads butting the tape on the side beads up to the tape on the bottom and top beads.

### FRAME DECORATION & MAINTENANCE

It is not generally recommended that the glazing materials are overcoated. Regular maintenance of the frame is essential to ensure maximum performance of the glazing system and double glazed unit.