



TECHNICAL INFORMATION SHEET

Glazing Slimline Glass Units with putty fronting into stained and painted timber frames.

Acorn Glass only recommend the use of bead glazing with Insulated Glass Units. However, there are several situations where units have to be glazed with putty fronting. Typical situations are in a listed building or where the glazing has to match existing. In such cases, it is suggested that one of the following glazing systems is used.

Glazing into painted timber frames

1. Seal the surfaces of rebates with Timber Sealer and allow to dry.
2. Apply Butyl 66 to the rebate; insert setting blocks and if space, distance pieces.
3. Centralise the glass in the frame on the setting blocks. Press firmly around the edge of the glass to engage the distance pieces or until the thickness of the compound is $1/2\text{mm}$. Insert location blocks if required.
4. Fill the perimeter void around the edge of the unit with Silfix U9 and secure the unit with glazing pins.
5. Apply Metal Casement Putty onto the platform and knife off at an angle finishing about 2 mm below the sight line.
6. Knife off the back bedding of Butyl 66 sloping away from the glass.

GLAZING METHOD No.1

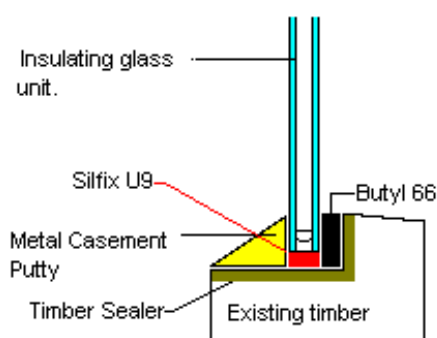

If a microporous paint finish is to be used Colourglaze must be used instead of the Metal Casement Putty.

Glazing into stained timber frames

1. Seal the surfaces of rebates with Timber Sealer and allow to dry.
2. Apply *Flexistrip* to the rebate and insert setting blocks. Butyl 66 can be used as an alternative to the Flexistrip.
3. Centralise the glass in the frame on the setting blocks. Press firmly around the edge of the glass to engage the Flexistrip. Insert location blocks if required.
4. Fill the perimeter void around the edge of the unit with Silfix U9 and secure the unit with glazing pins.
5. Trim back the Flexistrip or knife off the Butyl 66 such that it finishes inline with the sightline.
6. Apply Colourglaze onto the platform and knife off at an angle finishing about 2 mm below the sight line.

GLAZING METHOD No.2

